

KDR Gravity Flow Rack



USA HEADQUARTERS
Schaefer Systems International, Inc.

Shipping Address
10021 Westlake Drive
Charlotte, NC 28273

Mailing Address
P.O. Box 7009
Charlotte, NC 28241

Tel: 704-944-4500
Fax: 704-588-1862

PACKAGING SYSTEMS DIVISION
USA, CANADA, MEXICO

961 Beasley Street
Suite 120
Lexington, KY 40509

Tel: 859-294-5615
Fax: 859-294-5616
Toll Free: 888-SSI-TOTE
Email: packaginghelp@ssitote.net

Customer Service
Tel: 704-944-4583
Fax: 704-944-4582

Email: general@ssimail.net
www.ssi-schaefer.us

KDR Gravity Flow Rack

KDR Gravity Flow Rack is an excellent compliment or alternative to our innovative static shelving systems, SSI Schaefer has taken the traditional incline shelf and roller live storage principle in KDR, the ultimate non-powered storage and retrieval system.

Gravity Flow Rack greatly reduces travel time and in-creases order fulfillment speed while providing an or-ganized and high-density storage system.

Specifically designed for fast moving small to medium size parts with high volume, the KDR System provides the perfect blend of heavy-duty ruggedness and ergo-nomics, making it ideal for use in assembly line-side operations as well as traditional first-in/first out applications.



Upright Frames 78.75"

Order #	For Level Depth	Overall Depth
KRP63.0850C	41"	33.5"
KRP63.1250C	61"	49.25"
KRP63.1450CH	76"	57"
KRP63.2150C*	96"	84.5"
KRP63.2550C**	123"	100.5"

Frames ship assembled

All frames include 2 anchors, 2 shims and 2 top caps

* Consists of (1) 850 + (1) 1250 frame with 2" spacer

** Consists of (2) 1250 frame with 2" spacer

Cross Support Beams

Order #	For Bay Width
K.AT1350C	53"
K.AT1800C	71"
K.AT2200C	87"
K.AT2700C	96"

Add 4.75" to bay width for starter

Add 2.375" to bay width for add-on

KDR Gravity Flow Rack

Gravity Flow Rack Advantages

- The fore-to-aft positioning of the flow levels side can be adjusted in 1" increments providing individualized ergonomic curve relieving worker stress
- Flow rack levels can be adjusted in 0.25" increments in height providing maximum storage density
- Rollers and guides can be adjusted across the width of the levels in 0.18" increments enabling the use of any container
- Fully compatible with Schaefer containers
- Flow racks are available in 4 widths and 5 depths to fit into any available space
- Can be easily integrated with a Schaefer Pick by Light system



Rear Mounting Clip & Bracket



Adjustable Tilt Front Outlet Chute

Accessories

Order #	Description
KDR.TOPCAP K.AHS1 K.VH1	Top Cap Set Anti-Tip Clip Level Clip
K.SA1	Rear Clip

* For one frame upright—two posts

Flow Levels, Rollers & Guides

Level	Order # Roller	Guide	Bay Width	Level Depth	Capacity
KDRSL.041053	KR28S.0970C	KTL.0955C	53"	41"	1,000 lbs.
KDRSL.061053	KR28S.1470C	KTL.1455C	53"	61"	1,000 lbs.
KDRSL.076053	KR28S.1845C	KTL.1830C	53"	76"	1,000 lbs.
KDRSL.096053	KR28S.2445C	KTL.2430C	53"	96"	1,250 lbs.
KDRSL.123053	KR28S.3045C	KTL.3030C	53"	123"	1,000 lbs.
KDRSL.041071	KR28S.0970C	KTL.0955C	71"	41"	950 lbs.
KDRSL.061071	KR28S.1470C	KTL.1455C	71"	61"	950 lbs.
KDRSL.076071	KR28S.1845C	KTL.1830C	71"	76"	950 lbs.
KDRSL.096071	KR28S.2445C	KTL.2430C	71"	96"	950 lbs.
KDRSL.123071	KR28S.3045C	KTL.3030C	71"	123"	1,250 lbs.
KDRSL.041087	KR28S.0970C	KTL.0955C	87"	41"	800 lbs.
KDRSL.061087	KR28S.1470C	KTL.1455C	87"	61"	800 lbs.
KDRSL.076087	KR28S.1845C	KTL.1830C	87"	76"	800 lbs.
KDRSL.096787	KR28S.2445C	KTL.2430C	87"	96"	950 lbs.
KDRSL.123087	KR28S.3045C	KTL.3030C	87"	123"	1,250 lbs.
KDRSL.041106	KR28S.0970C	KTL.0955C	106"	41"	650 lbs.
KDRSL.061106	KR28S.1470C	KTL.1455C	106"	61"	650 lbs.
KDRSL.076106	KR28S.1845C	KTL.1830C	106"	76"	650 lbs.
KDRSL.096106	KR28S.2445C	KTL.2430C	106"	96"	750 lbs.
KDRSL.123106	KR28S.3045C	KTL.3030C	106"	123"	750 lbs.

Note: Levels do not include rollers and guides
 Each level includes 4 support clips and 2 rear adapter clips
 Each roller and guide come with 2 connecting clips
 For useable depth, deduct 3" from level depth
 For useable width, deduct 2" from bay width

Gravity Flow Rack Ergonomic Features

- Easy to assemble or reposition
- Upright frames ship assembled
- Cross beam drop simply into the uprights
- Front and rear of each level has only two bolts each for rapid assembly
- Center supports simply drop in
- Rollers and guides snap and lock in
- Sides of the levels are slotted in 1" increments to easily create optimum picking curves

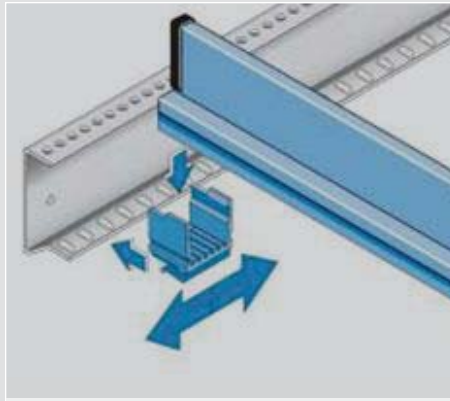

Standard full depth roller track KR28S

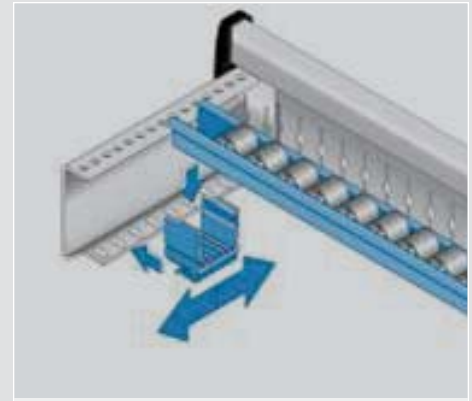

Standard full depth guide KTL

Gravity Flow Rack Heavy-Duty Features

- Frames have pallet rack columns 2.75" square
- 5,500 lb. cap. load capacity per rack
- Cross beam are structural steel C channels with welded-on flanges for maximum strength
- Roller tracks are constructed of galvanized reinforced steel with 12 bends to provide maximum strength and resist twisting
- Rollers are high-density injection molded thermoplastic 1" wide and 1" in diameter
- Rollers are equipped with independent full width steel wheel axels 0.125" diameter and provide a 26 lb. load capacity each
- Clips to hold rollers and guides wrap around sides and top to prevent twisting by a unique tongue and groove design

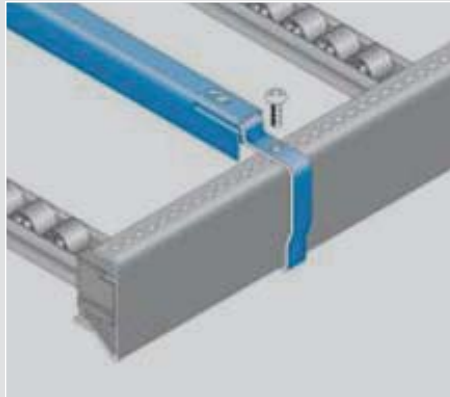

Full depth top guide rail KMT

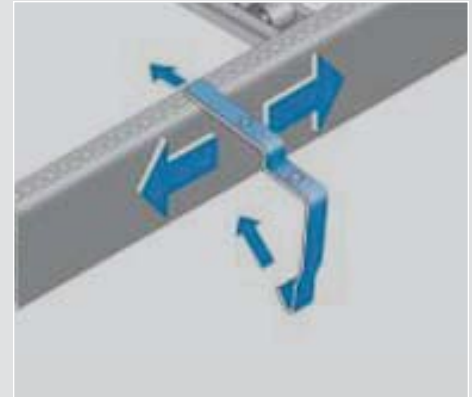

Load guide K.EW1 3" deep

Alternate Guide Rails

Order #	For Level Depth	Description
K.EW1	Any	Load Guide 3"
KMT.1025	41"	Top Guide
KMT.1525	61"	Top Guide
KMT.1900	76"	Top Guide
KMT.2500	96"	Top Guide

KDR Gravity Flow Rack

Gravity Flow Rack Features

Adaptor clips are available that can be used with roll-formed pallet rack frames to convert 96" wide pallet rack bays to gravity flow rack for "supermarket" type operations.

Clips drop into the slots or holes that are in 2" increments on the upright post. Please call SSI Schaefer to verify integration of clips into the racking frames.



Flow Levels, Rollers & Guides

Level	Order #		Level Depth	Capacity
	Roller	Guide		
KDRSL.052096	KR28S.1270C	KTL.1255C	52"	1,200 lbs.
KDRSL.096096	KR28S.2445C	KTL.2430C	96"	2,400 lbs.

Note: Levels do not include rollers and guides

52" D levels includes 4 support clips and 4 adapter clips

96" D levels includes 6 support clips and 6 adapter clips

Each roller and guide come with 2 connecting clips

Flow Lane Width Configurator (to determine optimum bay width)

Clear Width	Flow Lane Clear Width (using 1 guide between lanes)							
	2 Lanes	3 Lanes	4 Lanes	6 Lanes	7 Lanes	8 Lanes	9 Lanes	10 Lanes
53"	25.4"	16.8"	9.9"	8"	6.9"	6"	5.3"	4.7"
71"	34.3"	22.7"	13.4"	11.1"	9.4"	8.2"	7.2"	6.5"
87"	42.1"	27.9"	16.6"	13.7"	11.7"	10.2"	9"	8"
96" (for Rack)	46.5"	31"	18.5"	15.2"	13"	11.2"	10"	8.8"
106"	52"	34.5"	20.5"	17"	14.5"	12.6"	11.2"	10"

Contact SSI Schaefer for a wide variety of special applications such as mobile units, single lane "shooters" outlet chutes or any special sizes.